

Accurate. Reliable. Cost Effective.

Emissions Monitoring for Compliance & Process Improvement



OPTICAL INSTRUMENTATION ACCESSORIES

Cemtek Instruments offers a wide range of accessories used with optical instrumentation and as direct replacement including. Please check with the factory at (877) 400-2298 for all of your requirements.

Weather Covers

To protect your investment in sensitive instrumentation, we manufacture protective weather covers in two styles. A **clam shell** cover set is a direct replacement for Land fiberglass covers that often fail prematurely due to exposure mounts directly to existing Land mounting plates. A **flip-up** style is also available which mounts directly to a stack port and is available in various sizes. Both styles are made of light weight aluminum with a special UV protective coating and stainless steel fittings.

NEMA4 Blower Box Assembly

Easily mounted to stack or wall, the integral ring blower, filters, pressure transducers, electrical connections and hosing are all contained within a weather tight NEMA4 enclosure. A hinged door is provided for easy access and service. Connections are via simple 1.5 inch nominal pipe end for 2 inch hose connection. Available with optional external indicator lamps for visual confirmation of operation. Separate ring blowers are available as stand alone in three different sizes.

Filter and Pressure Switches

Replacement air filtration elements and pressure switches to monitor pressure drops usually indicative of blower failure or clogged filters.

Replacement Ring Blowers

Direct replacement ring blowers are available for a variety of output rates and electrical services. We offer three standard types with a variety of output rates and electrical services are detailed on page 2. While we recommend the use of NEMA4 Blower Box Assemblies, these replacement ring blowers may be installed where it can be certain that environmental exposure will not adversely affect the product and where a reliable, clean, dry, oil-free source is available.

Available Accessories

- Instrumentation weather covers
- Differential pressure switches
- Blower box assemblies
- Blower motors
- High volume coaxial air purges
- Air filtration cartridges and accessories



*Clam Shell
Weather Covers*

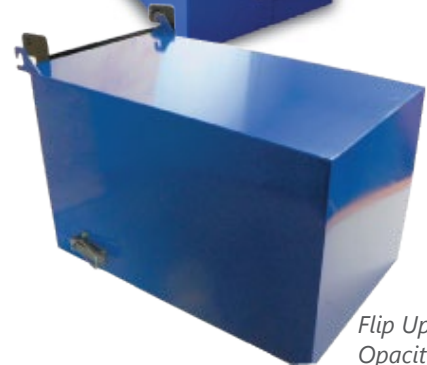

*Flip Up
Opacity Covers*

www.cemtekinstruments.com

STANDARD RING BLOWERS

Ring blower motors are available in a variety of sizes and electrical connections. In general, we require the smallest ring blower that can easily source enough air pressure to overcome any back pressure from the stack end. This back pressure may be considerable and vary over time.

	RB200	RB400	RB750
Power (VAC)	110	110	110
Current (A)	3	5	10
Flow (CFM) Outlet	21	46	88
Max Pressure (psi)	1.3	1.7	2.1
Weight (lbs)	21	29	37

*Weights given are for ring blower motors alone and are not for NEMA4 Blower Box Assembly.

BASE PLATE MOUNTED BLOWER ASSEMBLY

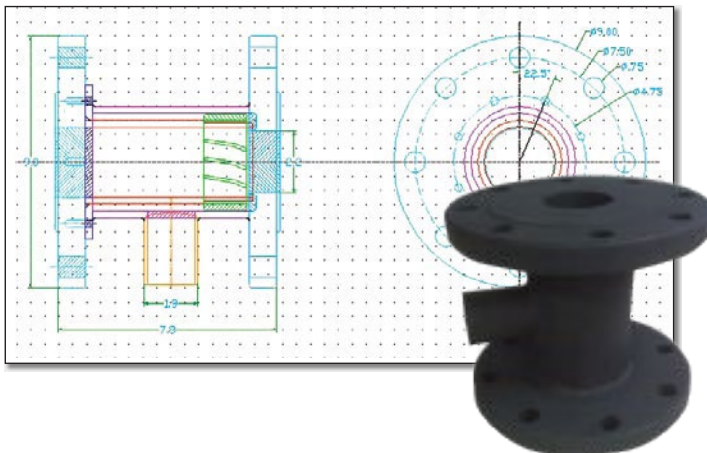
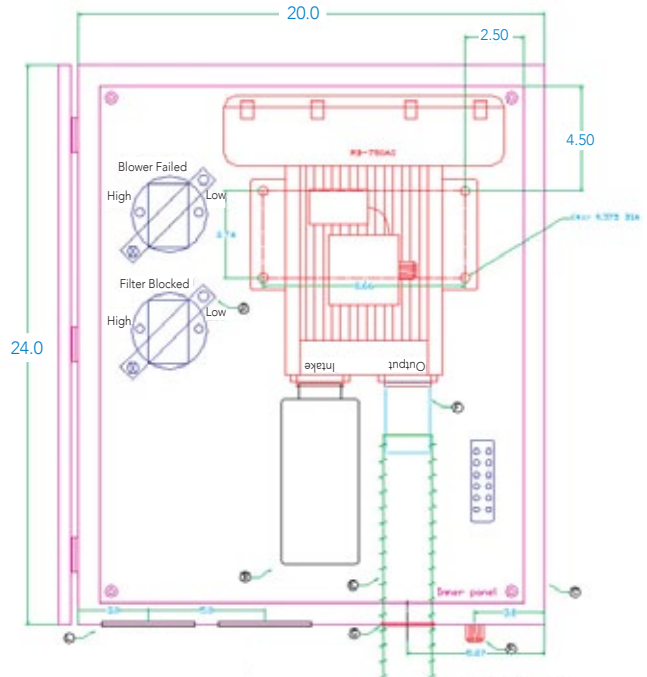

COAXIAL PURGE ADAPTERS

Used to keep optical instrument lenses clean, our custom coaxial purge adapters create a natural spin air flow from a source of pressurized air. Source may be either clean factory air or our ring blower assemblies. Available in aluminum or steel and in standard flange sizes, the coaxial purge adapters can withstand high temperature and pressure (>15 inches WC) in order to overcome significant stack pressures. The coaxial purge adapters are compatible with almost any optical instrument including: opacity, TDL and cross duct monitors.

